

**TIANJIN GREWIN TECHNOLOGY CO.,LTD.**

Web:[www.grewin-tech.com](http://www.grewin-tech.com)

WhatsApp:+86-13072088960

Email:salesmanager@grewin-tech.com

## **RCI-602 CABLE IDENTIFIER**

**\*Support running cable identification**

---

© We reserve all right in this document and in the information contained within.  
Reproduction, use or disclosure to third partners without express authorization is strictly  
forbidden. V 1.0



Address:DongLi Distr Tianjin City, China **Tel:+86-22-84943756** 0

# BEFORE USING



For different countries and zones, we try to offer different user settings for choice. Now the power system frequency and depth measurement unit is optional.

1. Factory setting: default power frequency 50Hz
2. Optional setting as below:

Check the receiver panel as below:

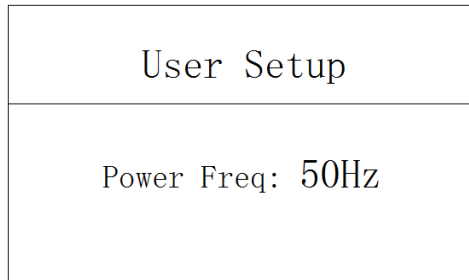
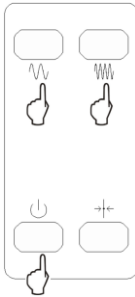
When the receiver power off, press Frequencies reduce button  and frequencies increase button  together, at the same time press the ON/OFF button  to power on the device and the Welcome interface will appear. Don't release buttons until below user setting interface appear.



3. Press Set ref. button  to set the Power freq. to 50Hz or 60Hz.
4. After setting long time press ON/OFF  button to power off device to finish the setting.
5. Customized setting will be kept when power off. If needed to change setting, modify it again following above steps.

## 1. GENERAL DESCRIPTION

## 1.1 GENERAL :

RCI-602 is a high performance cable identification system. It consists of a transmitter and a receiver, which can be used for both running cable and dead cable.

Running cable should be three-core sheath cable and it is high accuracy and easy to use.



Fig.1.1 device appearance

## 1.2 FUNCTION FEATURE:

- Used for both running cable and dead cable. Running cable should be three-core sheath cable.
- 50Hz/60 Hz cable load current measurement function.
- Multiple signal output method: direction connection and clamp coupling.
- High power output and adjustable with auto impedance matching and auto protection.
- Identification function: to display the identification result directly.
- All-digital high accuracy sampling process with narrow receiving transmission bands, high anti-jamming capability to fully inhibit the inference from the nearby running cable and pipe power frequency and harmonic wave.
- Big capacity Li-ion batteries series, support auto power off when low battery or long time no operation.
- Solid case and light weight easy to carry.

## 1.3 SPECIFICATION:

### 1.3.1 Transmitter:

- Output: Direct Connection output, Clamp Coupling Output
- Output Frequency: 640Hz (complex frequency), 1280Hz (complex frequency).



- Impedance levels adjustable, auto impedance matching.
- Output Voltage: 150Vpp.
- Output Impedance: 50Ω.
- Power: 10W.
- Battery: 2 X 18650 Li-on batteries, standard 7.4V, 6.8Ah.

### 1.3.2 Receiver:

- Input: soft flexible clamp
- Receiving frequency:
  - Active frequency: 640Hz, 1280Hz
  - Power frequency: 50Hz/60Hz
- Cable identification mode: soft flexible clamp
- Power frequencies measurement: range AC 1-1000A, accuracy +/-3%
- HMI: 800X480 LCD, size 121x76mm
- Built-in battery: 2 X 18650 Li-on batteries, standard 3.7 V, 6.8 Ah

### 1.3.3 Other:

- Volume: transmitter 280x220x90mm, receiver 220x125x55mm
- Weight: transmitter 2.3kgs, receiver 0.9kgs
- Charger: transmitter input AC 100~240V, 50/60Hz, output DC 8.4V, 2A  
receiver input AC 100~240V, 50/60Hz, output DC 5V, 2A
- Temperature: -10-40°C, humidity 5-90%, elevation <4500m

## 1.4 DEVICE COMPOSITION:

### 1.4.1 Transmitter:

Fig.1.2 transmitter appearance

2. LCD display
3. Keyboard
4. Output port
5. Charge port

1.4.2 Receiver:

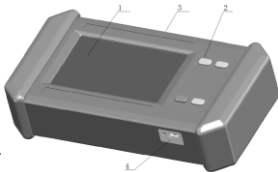

Fig

1. LCD display
2. Key buttons
3. Output port
4. Charge port

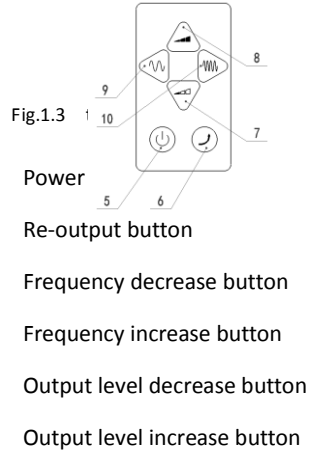

Fig.1.3

1. Power
6. Re-output button
7. Frequency decrease button
8. Frequency increase button
9. Output level decrease button
10. Output level increase button

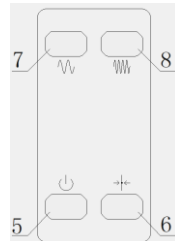

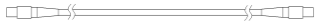



Fig.1.5 receiver buttons

5. Power on/off and mute button
6. Set ref. Button
7. Frequency decrease button
8. Frequency increase button

1.4.3 Standard accessories:

Item	Accessories name	Reference fig. And description	Qty
------	------------------	--------------------------------	-----

1	Transmitter direct connection output cable		1
2	Grounding rod		2
3	Earth extension cable	-	1
4	charger		2
5	Transmitter accessories output cable		1
6	Transmitter clamp		1
7	Receiver soft clamp		1

## 2. COMMON SIGNAL OUTPUT MODE

This chapter mainly introduces the common signal output mode: Direct connection mode, Clamp coupling mode and Radiation mode.

In the following chapter 3, we will do detailed introduction.

### 2.1 DIRECT CONNECTION MODE:

This method is to connect the output cable directly to the metallic pipe and inject the signal. It adapts the water pipeline, gas pipeline, telecom cable, power cable, cathodic protection pipe testing point and other access points, and other line characteristics continuous metal structure..

Compared with other mode, this mode will get the max. transmission current for better testing result. We suggest to use this mode condition permit.

#### 2.1.1 Direct connection mode connection diagram

\*Noticed: connect the red five-core plug into the output socket of the transmitter

\*Noticed to locking well all the plugs and sockets!

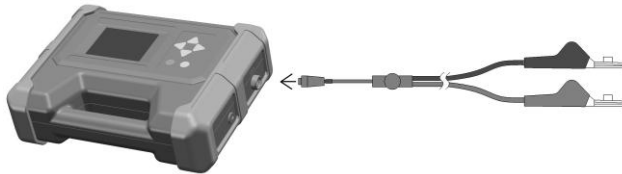



Fig.2.1 Main unit and accessories cable connection diagram

#### WARNING !

transmitter max. output voltage is 150vpp! don't touch the output clip and target pipe when working!

#### 2.1.2 Interface introduction and pipe voltage measurement

Long time press ON/OFF button  to power on the transmitter. If no accessories

connection the screen will display as below.

Fig.2.3 Pipe voltage measurement interface

If device with accessories and under the directly connection mode, device will first do pipe voltage measurement and display as below:

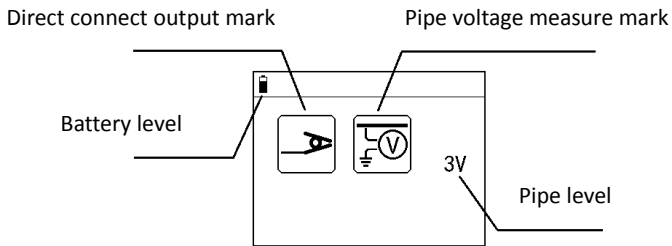
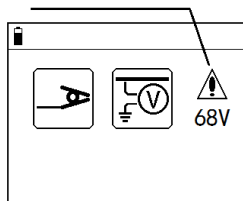

Fig.2.4 Over voltage alarming interface

If pipe voltage over limitation 50V, device will keep the voltage measurement interface without signal output and display the alarming mark as below:

Over limit alarming mark



If voltage is normal, device automatically outputs signal after several seconds. Screen display as below:

Battery level



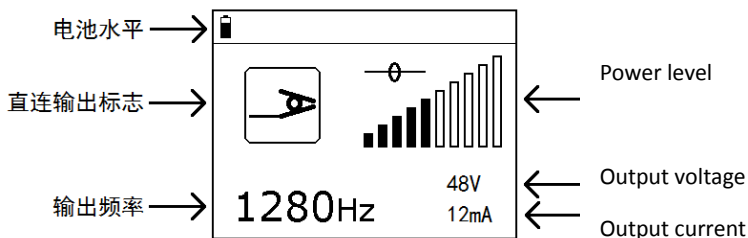





Fig.2.5 Direct connection output interface

### 2.1.3 Frequency selection

Press frequency decrease button  and frequency increase button  to select the transmitting frequency. Two frequencies could be selected: 640Hz, 1280Hz. Default power on frequency is 1280Hz. Some selection suggestions:

- Common good grounding cable and pipe, suggest to use the default 1280Hz. It can complete most of the testing requirements.
- Choose low frequency such as 640Hz, to do long pipe route tracing. The low frequency has long transmission distance and not easy to induce to other pipe. And this two frequencies is complex frequency support tracing error/correct indication.

### 2.1.4 Adjust output power level

Press output decrease button  and output increase button  to adjust the output levels (total 10 levels). The right down corner will display voltage and current.

Adjust output levels according to different requirements:

- Big current contributes to detection stabilization and veracity.
- Decrease output power is contribute to extend battery using time.

## 2.2 CLAMP COUPLING MODE:

This method is used for the naked Pipes while it is difficult or unable to reach the metal

part, and both ends grounded, especially useful for the power cables.

The clamp coupling mode is easy to use and no need electrical connection so no effect to pipe normal running and will reduce the induce to other pipe. But the coupling current is smaller than direct connection mode, require pipe both ends good grounding, this doesn't apply to all cases.

### 2.2.1 Accessories connection

Assemble transmitting clamp as below:

Use the red connection cable to connect the clamp and the transmitter output port

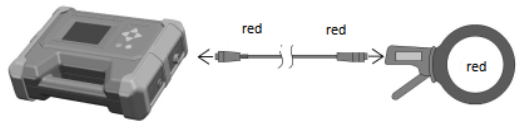

Fig.2.6 Clamp coupling accessories connection diagram

### 2.2.2 Clamp the pipe naked part as below:

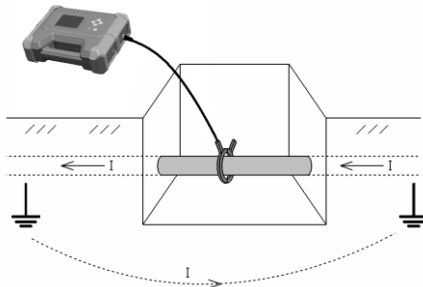

Fig.2.7 Clamp coupling mode wiring

### 2.2.3 Interface introduction

Transmitter power on and will automatically check the accessories and enter the clamp coupling mode. Screen display as below:

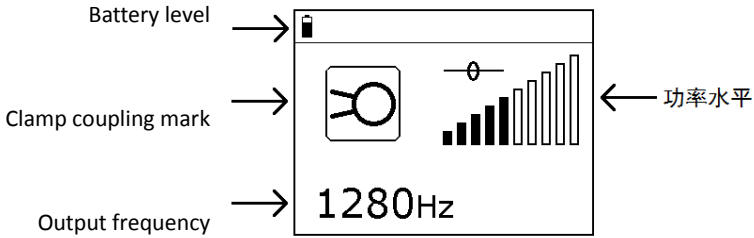



Fig.2.8 Clamp coupling output interface



#### 2.2.4 Frequency selection

Press frequency decrease button  and frequency increase button  to choose the transmitting frequency.

Total two frequencies: 640Hz,1280Hz.default 1280Hz.

Clamp coupling mode frequency selection method is same as direct connection mode.

#### 2.2.5 Output power adjustment

Press output decrease button  and output increase button  to adjust the output levels(total 10 levels).

The current coupled to the pipe is much lower than direct connection mode,so to use the max. level output.

Clamp coupling mode can't display the coupled voltage and current.

### 3. SIGNAL TRANSMITTING METHOD FOR CABLE IDENTIFICATION

The cable identification is very important function of pipe/cable detection. Compared with the single and continuous metal structure of pipe, the cable is composed by several

cores and metallic armor. These construction and use differences make signal applying method different and different connection method will make different electromagnetic field then different detecting result. So this chapter will introduce the cable detection signal transmitter method individually.

### 3.1 SIGNAL TRANSMITTING METHOD FOR DEAD CABLES

#### 3.1.1 Basic connection method: Conductor-Earth

Conductor-Earth connection is the best connection method for cable identification for dead cables. It will give full play to the device function and reach max. anti-interference performance. Refer below fig.3.1

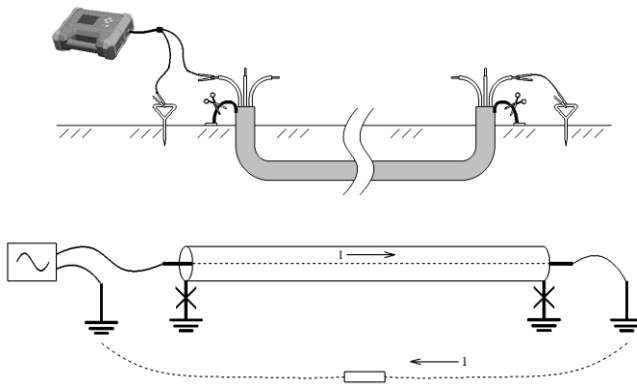

Fig.3.1 Conductor-Earth Connection Method

Loose the sheath of the both ends of the cable, also disconnect the earthing of Null line and Grounding line. Clamp one good conductor with the RED CLIP , and clamp the grounding rod with BLACK CLIP, connect the other end of the cable conductor to the grounding rod. At the cable opposite end, connect the core line with the grounding rod insert in the earth.

**Attention: Use grounding rod, do not use grounding network! At least use grounding**

**rod for the other end of the conductor, and the grounding rod should be away from the grounding network. Otherwise the earth wire back flow will effect the detecting result.**

The current travels from the Transmitter, flows through the conductor and earth at the far end, then travels back to the transmitter. This connection method will make the receiver induce strong signal with clear character. There will be strong signal flows through the well isolated conductor, it will not flow to nearby pipelines, especially the crossing metal pipelines, it specially applies to the identification under complex environment.

In addition, the cable is grounded, so the signal voltage flow through cable is low, which can not interfere other instruments.

Because there is distributed capacitance between conductor and earth, the current will attenuate when flows from this end to the other end, but if it is well earthed, the leaked current will be very low, we can ignore it.

The shortage for this connection method is that it needs to disconnect the grounding line for the both ends of the cable and seems a little too complicated.

### 3.1.2 Sheath-Earth Method

As below Fig. 3.2 shows, loose grounding cable of the sheath of the near end of the cable, also loose the earthing of Null line and Grounding line of the low voltage cable, keep the sheath of the cable grounded at the far end. Then to apply signal between the sheath of the cable and the Grounding Rod (Do not use grounding network), and keep the conductor hung in the air. The current travels from Transmitter, then flows through the sheath and goes to the earth at the far end, then travels back to the Transmitter. This way, there will be no shielding, the signal to the ground is strong, and the signal character is clear. Also, because the distribution capacitance exists, the signal attenuates

from the near end to the far end.

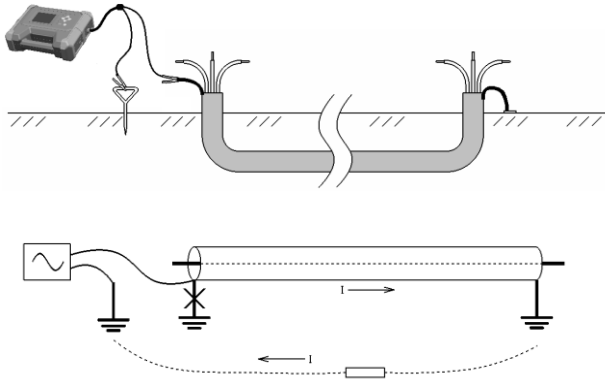

Fig.3.2 Sheath-Earth Method

The potential problem for this connection method is if sheath breakage, the current may go to the earth at the breakage point to make the signal received will have a sudden decrease at the breakage point, and the decrease level depends on the grounding resistance at the breakage point.

### 3.1.3 Phase-Sheath Method

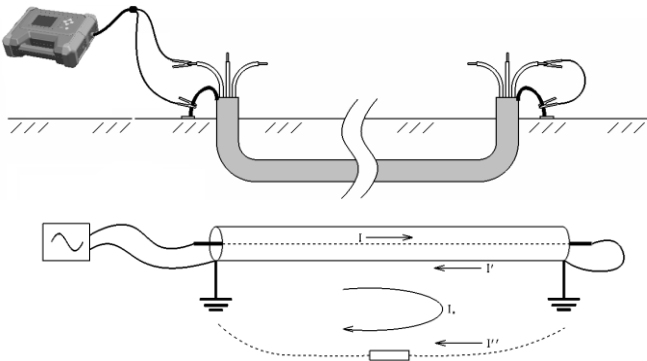

Fig.3.3 Phase-Sheath Method

As above fig.3.3 shows, signal is applied between cable one phase and sheath, short the far end phase and sheath, keep the both ends of the sheath grounded.

If it is one cable, the signal will flow from the Transmitter to the conductor, and return

through sheath and earth. Because the sheath has low resistance while earth has high resistance, most of the current will flow back via sheath and only little returns through earth. Because the direction of conductor current and sheath current reverse, the difference equals the virtual current which generates electromagnetic signal in external with some distance. The value equals the resistance current back through the earth. Because the induction of Conductor-Sheath loop and Sheath-Earth loop, the current will also be generated by electromagnetic. The end effect is the virtual current equals the vector addition of earth loop resistance current and induction current. For different field condition, the virtual current is about only a few percent to lower than twenty percent of the injected current.

If there're other same path cables (with same end positions), the return current will be shunted by these cable sheaths. For example, if there're three cables in same path, the sheath return current of every cable is  $\frac{1}{3}$ . The virtual current is positive and the value is about  $\frac{2}{3}$  of the injected current, while the nearby current is passive and value is about  $\frac{1}{3}$ . Refer below Fig. 3.4

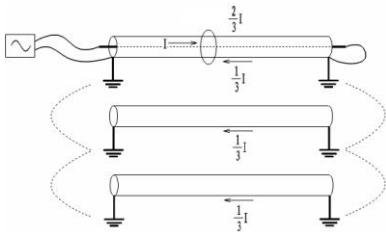

Fig.3.4 External effect:  $\frac{2}{3} I$

The Phase-Sheath method is easy to connection, no need to loose the grounding cable. But when multiple cables lay in same path, the signal difference of different cables will not quite different not easy to distinguish only by signal amplitude.

When single cable lay, the effective current will sharp decrease, signal will be weak and effective current has induction current so the target cable has same induced signal phase with nearby pipes. If use the complex frequency, it maybe difficult to eliminate the disturbing signal according the current direction.

### 3.1.4 Select frequency

- Normally, use the default 1280Hz can fulfill the detection of most of the cables/pipes. It's low frequency and with long transmitting distance so not

easy to induce to other pipe. Also the receiver has better receiving effect for this frequency.

- For long distance cable/pipe (longer than 2-3Km), if use the 1280Hz, there will be very big attenuation if long distance. So we suggest frequency 640Hz.
- 640Hz and 1280Hz is complex frequency, under this two frequencies, device support tracing right/wrong reminding.

### **3.2 SIGNAL TRANSMITTING METHOD FOR LIVE CABLES**

#### 3.2.1 clamp coupling method

This is an ideal detection method for the live cables, no need to change the cable and very safe to operator; there is signal on the whole length of the cable, and no distance limitation.

**The both ends of the cable sheath should be grounded, or the coupling current will decrease while grounding resistance increases.**

**We can not use the clamp coupling method if the both ends are not grounded, or the sheath is broken.**

- Clip the cable

As below fig.3.6 shows, this method is useful for the detection of common three-phase power cable. Connect transmitter output with clamp and use the clamp to clip the cable (not clip the part above the grounding line). The clamp equals to transformer primary, cable metallic sheath-earth loop equals to secondary (single-turn). The coupling current is related to the loop resistance. The smaller resistance, the bigger current.

The cable current from clamp coupling is small. To strengthen detection effect, we



suggest choosing big output level.

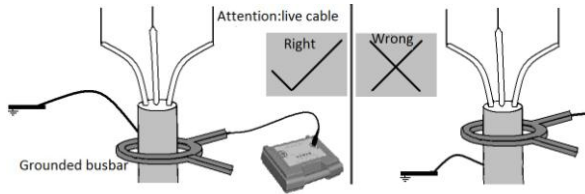

Fig.3.6Clamp coupling method 1 (to clamp the cable)

### 3.2.2 Null line/Ground line/Shield Injection method

This method is used for detection for the live low voltage cables, because most of the low voltages shield is not grounded, or the shield is not continuous, or it is not very well grounded, we can not use Clamp Coupling method.

This method no need to modify the cable, and because inject the high frequency, it will not effect the running line.

At the operator end, clip the null line, grounding line or shield with the red clip, and the black clip to the grounding rod. It is as Fig. 3.8 shows.

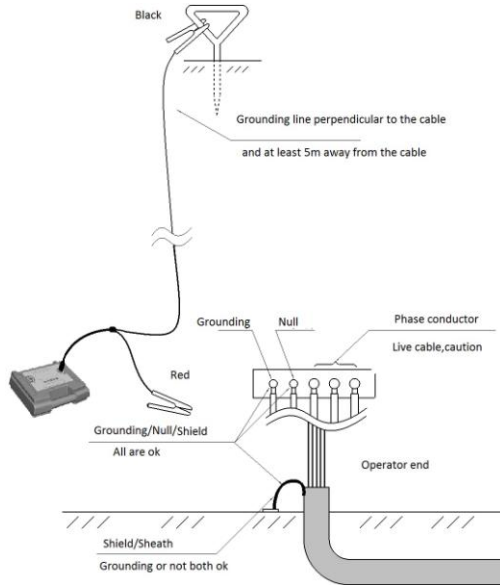

Fig.3.8 Null / Ground / Shield Injection Method



- The cable is live, there is power, the operator needs to be competent to do this work for cable connection.
- Please do connect the Transmitter at the operator end. If inject signal in the transformer end, signal will be injected in all the outlet cable and difficult to distinguish the target cable.
- The position of the ground rod: it should be at least 5m away from the pipe or cable, and keep the black cable perpendicular to the suspected pipe path.
- If the null cable is not grounded at the operator end, please preferentially use Null to inject signal.
- The shield maybe discontinuous for the low voltage cable, if the signal injected is too weak, or the signal is interrupted during the detection, we can

use the Null/Ground method to inject signal.

- When we detect the live high voltage cable, the signal is very weak or we can not receive signal using clamp coupling method, this shows that the shield ground resistance is too high at the double ends, for this condition, we can use Shield to inject the signal.
- For single conductor ultra high signal live cable, sometimes the clamp coupling method maybe not effective, we can use Shield Injection method.

#### **4. INTELLIGENT CABLE IDENTIFICATION**

In the power construction, the cable identification is a work with very strict requirements, because it is related facilities and personal safety. The intelligent soft clamp identification is the clearest, the most powerful anti-jamming method.

##### **4.1 Signal transmission method**

- The frequency of receiver must be settled as 1280 Hz or 640Hz. The fault frequency, 1280 Hz, can meet the most test requirement. If the cable is too long, you can use 640 Hz.
- For dead cable, you should select the direct connection method, and the best connection is core- ground connection; If it is not convenient to connect the cable, you also can use phase to sheath connection, don't use sheath to ground connection.
- For running cable, the best choice is clamp coupling method

##### **4.2 Accessories connection of soft clamp**

Assembling the soft clamp into the receiver input socket.As below 4.1

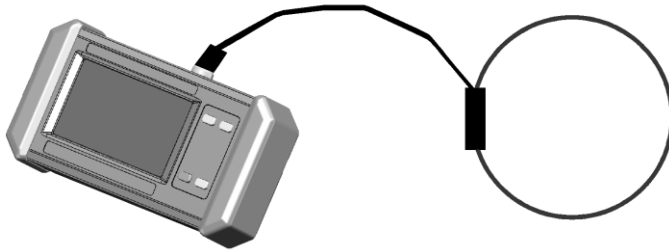

Fig.4.1 Soft clamp connection

### 4.3 Receiver interface introduction

Power on and the receiver will automatically identify the connected accessories and set as Clamp receiving mode as below:

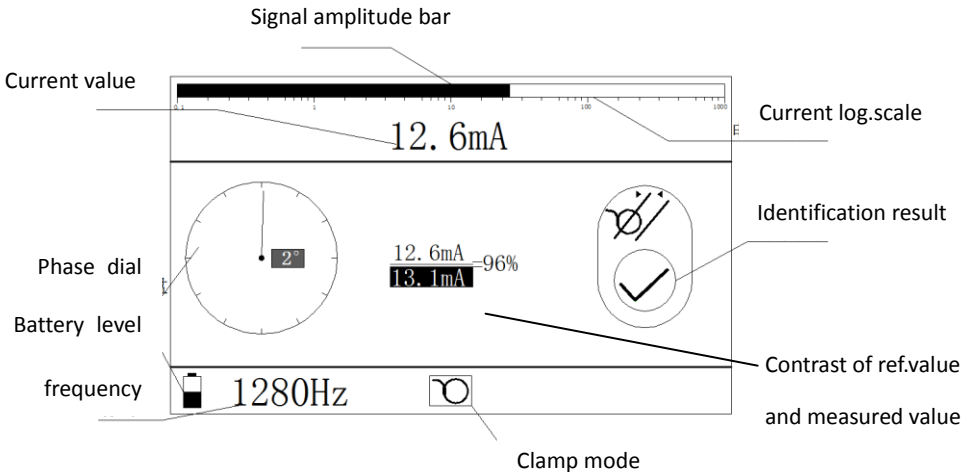



Fig.4.2 Clamp identification interface

Receiver default frequency is 1280Hz, we should set it same as transmitter. Under the clamp mode, we don't need to adjust the gain and device will directly display the current value and show it's percentage result with set reference current. Phase dial will display





the current phase. The identification result will display Correct  or Error .

#### 4.4 Set reference

Use the Set. Reference method, we first need to measure the target cable current intensity and phase in known position as reference. Compare the measured result of some point with this reference result to distinguish. The process of measurement and record the result of current and phase is called Set. reference.

The setting reference should near the receiver, and not be interfered by it. When using clamp coupling method to transmit signal, it should be leave the transmitting clamp at least 2m. The receiving clamp should lock the target cable.

**The direction arrow of clamp should point to cable terminal.**

Press the “Set Reference” button  of receiver, the screen will show:  on the right below corner to check whether to do clamp set reference. Press other button to cancel while press Set reference button  again to finish setting and now screen will display . Now the current phase returns to zero, pointer of phase dial points upward a, angle below dial will be  $0^\circ$  and at the same time the current value will be the compared and calculated denominator (reverse showing) . The indicate result sll be correct as 

This will be the benchmark for following identification. After setting reference, the data should be saved. If the instrument power off, the data should not lost. When identifying other cable, the reference must be reset for the new target cable.

#### 4.5 Identification

Leaving the reference point, arrive at the identified point, then using the soft clamp to lock the cable.

**Pay attention that the direction arrow of clamp should point to the cable terminal.**

If the locked cable is the target one, the current intensity and phase of measured point

will be similar with the reference point. If it meets the following standards, it will be the target cable:

- The current value is greater than 75% of reference value, and less than 120%.
- The phase difference of current doesn't exceed 45°

Then the identification result will be correct ✓

If it doesn't meet above standards, it is the neighboring cable, the identification result will error ✗

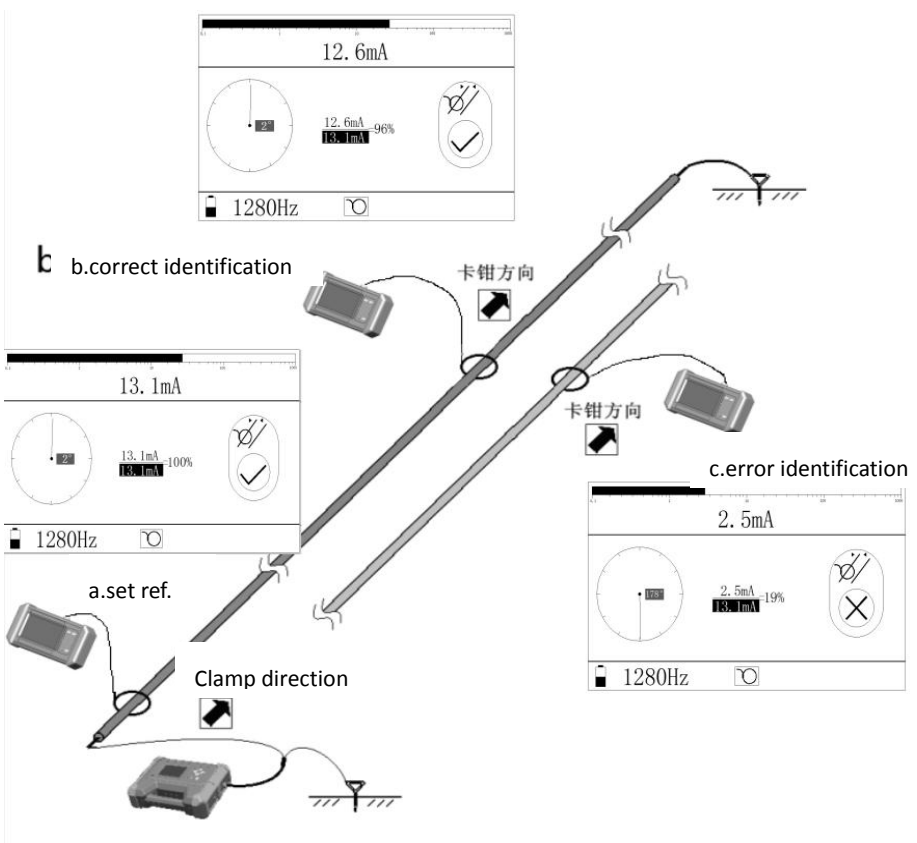

Fig.4.3 Clamp identification process



- When setting reference and identifying, the direction arrow of

receiving clamp must point to cable terminal and be closed well.

- The connection of core wire to ground is very complex, but the effective current in the target cable is the most, and less susceptible to interference by neighboring cable. Priority should be used. Example: current of target cable is  $I$ , phase is at  $0^\circ$  vicinity, identification is correct; current of neighboring cable is much less than  $I$ , phase is near  $180^\circ$  or unstable, identification is error.
- When transmitting the signal with phase to sheath connection, if no parallel cable, the effective current of target cable will be smaller; if have, the effective current of target cable will be the sum of other cables.
  - Example A: the path of 3 cables is same (including the target cable), the test result is: the current of target cable is  $I$ , phase is at  $0^\circ$  vicinity, identification is correct; the current of two neighboring cable is  $I/2$ , the phase is at  $180^\circ$  vicinity, identification is error ( as shown in Fig 3.4)
  - Example B: the path of 2 cables is same (including the target cable), the test result is: the current of target cable is  $I$ , phase is at  $0^\circ$  vicinity, identification is correct; the current of neighboring cable is  $I$ , the phase is at  $180^\circ$  vicinity, identification is error. Because the current is same, the identification is only by the phase, and also should pay attention the clamp direction
  - Example C: the cable is parallel with the target cable, but the path is not same (generally, the terminals are in different position ), the test result is: the current of target cable is  $I$ , but the value is smaller than injected, phase is at  $0^\circ$  vicinity, identification is correct, the current of neighboring cable is near to 0, phase is near to  $180^\circ$  or unstable, identification is error (as shown in Fig 3.3).

- If transmitting the signal with sheath to ground connection, if the insulating sheath was damaged, the current after the damaged point will be reduced. It will effect your judgment with current intensity criterion. So, not recommended.
- If transmitting the signal to running cable with clamp method, the transmitting clamp will radiate signal to space, and it will interfere receiving. So, when setting reference, the distance between transmitting clamp and receiving clamp must be 2~5m. Method to judge whether interfered: setting reference first, then unlock the cable and close the clamp in air at the same position. Observing the measured current value, if the value is much less than the reference and near to 0, that means the distance is enough; otherwise, should continue to increase the distance.
- If transmitting the signal to running cable with clamp method, the both ends of cable must be grounded well to form a larger coupling current. If the active current is small, check whether clamped the target.
- This method can't be used to identify single core UHV running cable. Power current through such single core cable is powerful, and no three cores cable phase offset effect. If clamp the cable itself, it's easy to make clamp magnetic saturation and can't receive the high frequency signal.

### **Safety Warning!**

- **As the cable identification involves facilities and personal safety, first, according to various on-site information (such as cable diameter) to**



## **5. POWER FREQUENCY CURRENT MEASUREMENT**

The power frequency measurement is widely used for power,telecom,oil field,building

and other industrial and mining companies.

It is used for measuring the site AC big current and leakage current.

## 5.1 INTERFACE

When power on the receiver will auto identify the connected accessories and set as clamp receiving mode.

Press frequency decrease button or frequency increase button to enter the power frequency measurement interface.

After connect the soft clamp and it is ready for current measurement.

## 5.2 POSITION ERROR

Make the tested line in the middle position of the soft clamp and not close to the open position as if in this position the error will at least increase for one time.

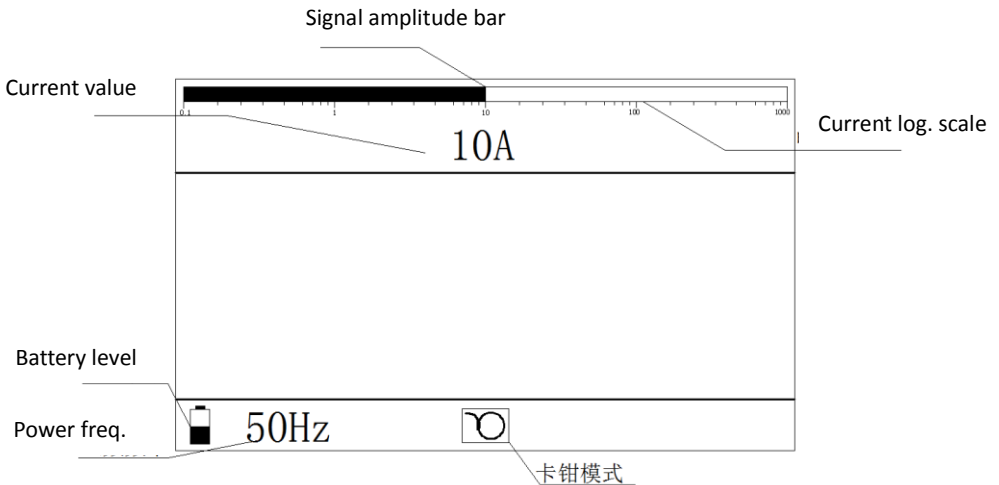



Fig.5.1 power frequency measurement interface

## 6. DEVICE MAINTAIN AND WARRANTY

### 6.1 CHARGING

Device adopts built-in Lithium battery. According different output level the work time is also different. Common enough for 8 hours working every day.

During the using ,there will be a battery level indicating mark in the bottom left corner. The black bar instead battery level, all black means full power, all blank and flash means low battery level. When appear mark , instead power use up and will auto power off in several seconds.

If need charging, insert the charger plug into the transmitter/receiver Charge port. Charger AC plug connects 220V/110V mains supply.

When charging, if charger indicator is red it means in charging, while green means completed. Keep charging for some time is helpful for charging more power.

Under the power off condition, receiver charging from low battery to full needs about 3-4 hours and receiver needs about 2-3 hours.

According different using and maintaining condition, the battery group common supports 300-500 charging-discharging cycles. According the increase of charging-discharging, the battery capacity will gradually step down, corresponding the device working time will step down.

Change battery when need. Standard battery is 18650 Lithium battery, capacity is above 3400mAH, suggested the Panasonic NCR18650B(3400mAH) or larger capacity models.

Transmitter needs 4 PCS batteries, receiver needs 2 PCS batteries.

**Attention for the battery plus-n-minus when installation.**

## **6.2 WARRNATY AND MAINTIAN**

Device main unit and accessories are one year guarantee of free maintain, battery is one year free replacement.Beyond one year, only charge for basic component cost for

maintaining.

For device breakdown by incorrect using (in the warranty ) or device quality problems over warranty, we are responsible for maintaining and only charge basic component cost.

When auto power-off, unable to power on or immediately shut after power on, it's possible because low battery. Charging first and again.

If other problems,don't to maintain by yourself, contact with us first.

(manual version:V1.0 )